

**PIRAEUS  
BANK GROUP  
CULTURAL  
FOUNDATION**





# The Foundation

The Piraeus Bank Group Cultural Foundation (PIOP) is a voluntary non-profit foundation. In accordance with its statute, its operational costs, including those of its Museums, are covered by the Piraeus Bank Group. In parallel, PIOP pursues the co-financing of certain projects through national and European programmes.

**The basic statutory goals of the Foundation are:**

- to record and showcase Greece's tangible and intangible cultural heritage and identity.
- to preserve the traditional, artisanal and industrial technology of our country.
- to link culture with the environment and sustainable development.

**These goals are achieved through:**

- the creation and management of a Network of thematic Museums of technology in the Greek provinces.
- the organization of Historical Archives relating to the economic, banking, industrial and agricultural history of the land.
- the implementation of research programmes, the publication of academic works and special editions.
- the operations of a specialized Library, open to the public.
- the organization of a variety of academic and cultural actions.
- the implementation of educational programmes and activities, with an emphasis on schoolchildren.
- the use of new technologies.
- the collaboration with reputable Greek and international cultural and educational institutions.
- the participation in the public debate regarding strategies in the area of culture.

# The Museum Network

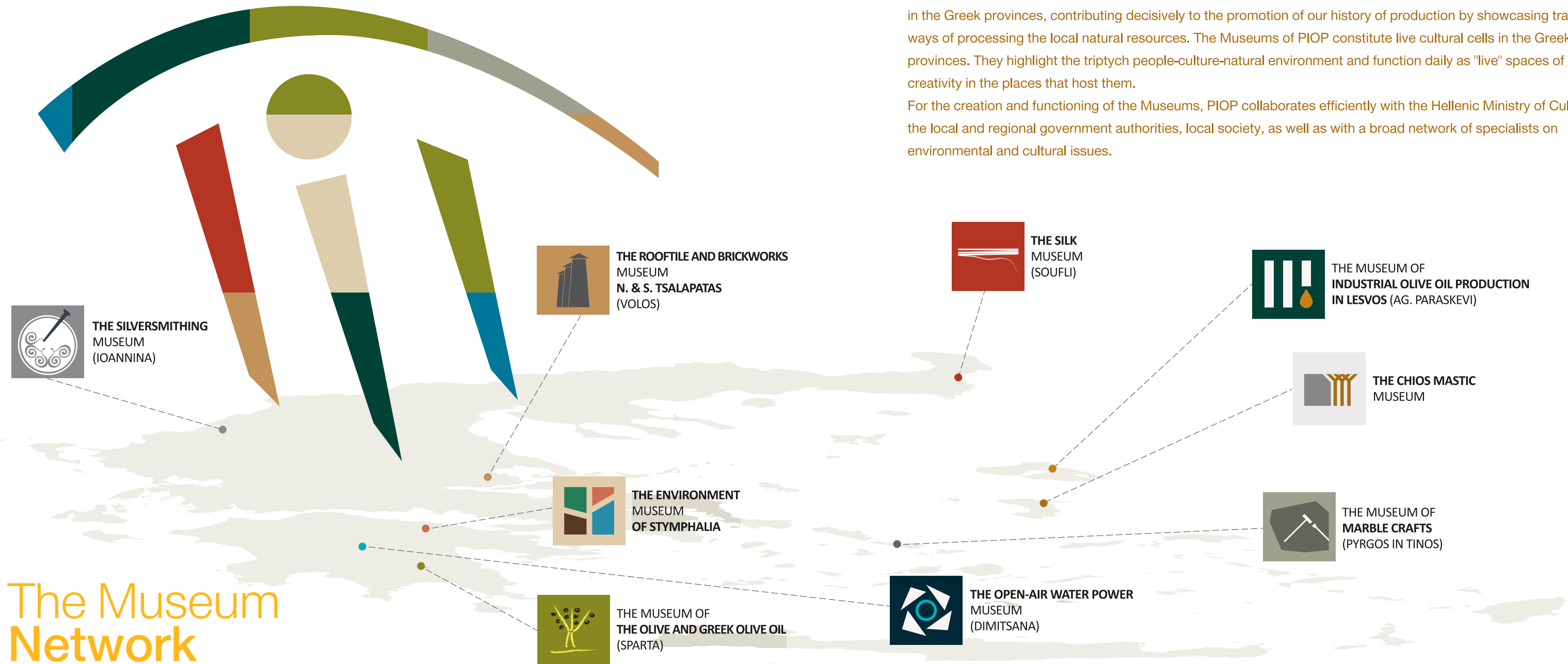

The Piraeus Bank Group Cultural Foundation (PIOP) has created and operates a Network of nine thematic Museums in the Greek provinces, contributing decisively to the promotion of our history of production by showcasing traditional ways of processing the local natural resources. The Museums of PIOP constitute live cultural cells in the Greek provinces. They highlight the triptych people-culture-natural environment and function daily as "live" spaces of cultural creativity in the places that host them.

For the creation and functioning of the Museums, PIOP collaborates efficiently with the Hellenic Ministry of Culture, the local and regional government authorities, local society, as well as with a broad network of specialists on environmental and cultural issues.

The **SILK**  
Museum



The Silk Museum in Soufli is housed in the Kourtidis Mansion, a building dating from 1883, and presents the stages of pre-industrial sericulture and silk manufacturing.

At the permanent exhibition of the Museum, visitors are informed about the multifaceted role of silk as a timeless feature of material culture, and they learn how Soufli became a significant silk production centre from the late 19th century until the mid-20th century. Visitors discover the processes of sericulture following all the stages, from the production and incubation of the silkworm's eggs to the dyeing and weaving of silk textiles. Finally, visitors also have the chance to admire traditional local costumes of Soufli and impressive costumes of the Chinese Opera, part of a collection that was donated to the Foundation by the Embassy of the People's Republic of China in May 2018.



The Open-Air  
**WATER POWER**  
Museum



The Open-Air Water Power Museum in Dimitsana highlights the importance of water power in traditional society. Focusing on the main pre-industrial techniques that utilize water for the production of a variety of goods, the Museum links these techniques to the history and daily life of the local society over the ages.

Visitors can tour the traditional workshops that are surrounded by dense vegetation and running waters. The first building houses a fulling-tub and a flour mill. Outside the mill a *rakí* cauldron is exhibited and right opposite at the tannery visitors can learn about the various stages of the leather-dressing process.

The cobbled road leads to a gunpowder mill which reminds the role of Dimitsana during the 1821 Revolution of the Greeks.



## The Museum of the **OLIVE AND GREEK OLIVE OIL**



The Museum of the Olive and Greek Olive Oil in Sparta presents the culture of the olive and olive oil as well as the technology of its production in the Greek provinces, from Pre-historic times until the early 20th century, highlighting the ineffable relation of the olive with our country and the Mediterranean in general.

Visitors have the opportunity to see the very first evidence of the presence of the olive tree in Greece (rare, fossilized olive leaves that are 50,000-60,000 years old) and olive oil production (copies of Linear B tablets dating from the 14th century BCE). Visitors can also discover the influence of the olive and olive oil on the economy and everyday life as well as their symbolic role in the mythology, religion, the manners and customs of the Greeks.

Furthermore, animated models and original machinery help visitors trace the evolution of technology over time in the field of olive oil production.



The Museum of  
**INDUSTRIAL  
OLIVE OIL  
PRODUCTION** in Lesvos



The Museum of Industrial Olive Oil Production in Lesvos, in the village of Aghia Paraskevi, presents the industrialisation of olive oil production in Greece, focusing on the changes brought about by the introduction of steam power to the process of olive oil production. In parallel, the Museum approaches with particular sensibility the initiative of the inhabitants of Aghia Paraskevi that led to the creation and operation of a pioneering communal oil press.

The aim of the Museum is to showcase the industrial heritage in the field of oil production by placing it in the wider framework of the architectural, social and cultural context of that era. The buildings and machinery of the steam-powered oil press have been restored in an exemplary fashion. In the former factory, functioning machinery and varied visual and digital constructions demonstrate the main stages of olive oil production: crushing the olives, compressing the pulp, separating the oil from the water. In addition, in the old olive-fruit warehouses the exhibition “unfurls” the whole spectrum of activities related to the cultivation of olive trees as well as the social and economic conditions of the era.



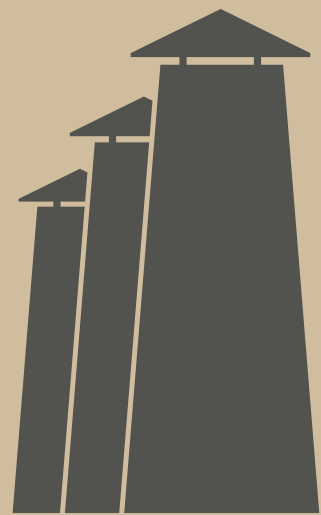

The **ROOFTILE  
AND BRICKWORKS**  
Museum  
**N. & S. TSALAPATAS**



The Rooftile and Brickworks Museum, in the city of Volos, is housed in the old Rooftile and Brickworks Factory of Nikolaos and Spyridon Tsalapatas. The restored spaces of the Museum are a rare example of an extant industrial complex.

Visitors follow the production process step by step: from the locomotives, the clay wash backs and the grinding mills, the production area of bricks and rooftiles with the presses and cutters, through the corridors of the drying chambers, up to the impressive Hoffmann kiln. In addition, daily life in the factory is depicted through the touching accounts by some of the last workers employed there.



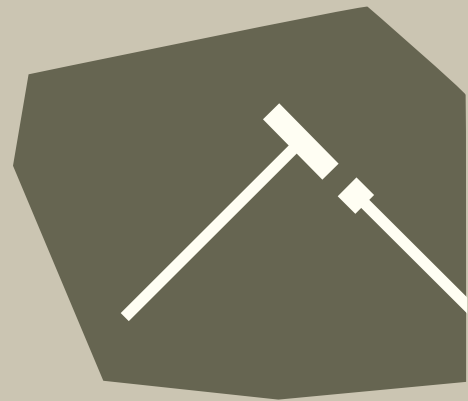

## The Museum of **MARBLE CRAFTS**



The Museum of Marble Crafts in the village of Pyrgos on Tinos island presents in a detailed manner the intricate meshing of tools and techniques used in working marble, with an emphasis on the pre- and proto-industrial Tinos.

In parallel, it highlights the social and economic conditions in which the local workshops developed. In the permanent exhibition of the Museum visitors can observe original creations made of marble (secular or ecclesiastical, funerary or everyday objects), clay models, plaster copies, tools and mechanical equipment. Visitors can also admire the rich collection of drawings by marble-carvers of yore, as well as the archival materials.

Finally, the impressive reconstructions of a quarry and a workshop, presented through audiovisual material, bring back to life the traditional working methods of a quarryman and a marble-carver. Tinian marble-carving has been inscribed on the Representative List of Intangible Cultural Heritage of Humanity by UNESCO (2015).





# The **ENVIRONMENT** Museum OF STYMPHALIA



The Environment Museum of Stymphalia, next to the lake in the mountainous Korinthia region that is familiar from ancient Greek mythology, aims to show the interdependence and harmonious co-existence of mankind and nature. Its objective is to raise the public's ecological awareness and preserve the knowledge of the region's traditional occupations.

The Museum presents information about the distinct environment of the area, included in the European Network of Specially Protected Areas Natura 2000. In addition, visitors can comprehend how this particular environment influenced the development of human activities and traditional occupations. The Museum displays a rich and wide array of information material, models, original digital representations and documentary films. A most impressive exhibit is the open sweet-water aquarium inside the building of the Museum, reconstructing the lake in cross-section with real flora and fauna from the area.



## The **CHIOS MASTIC** Museum

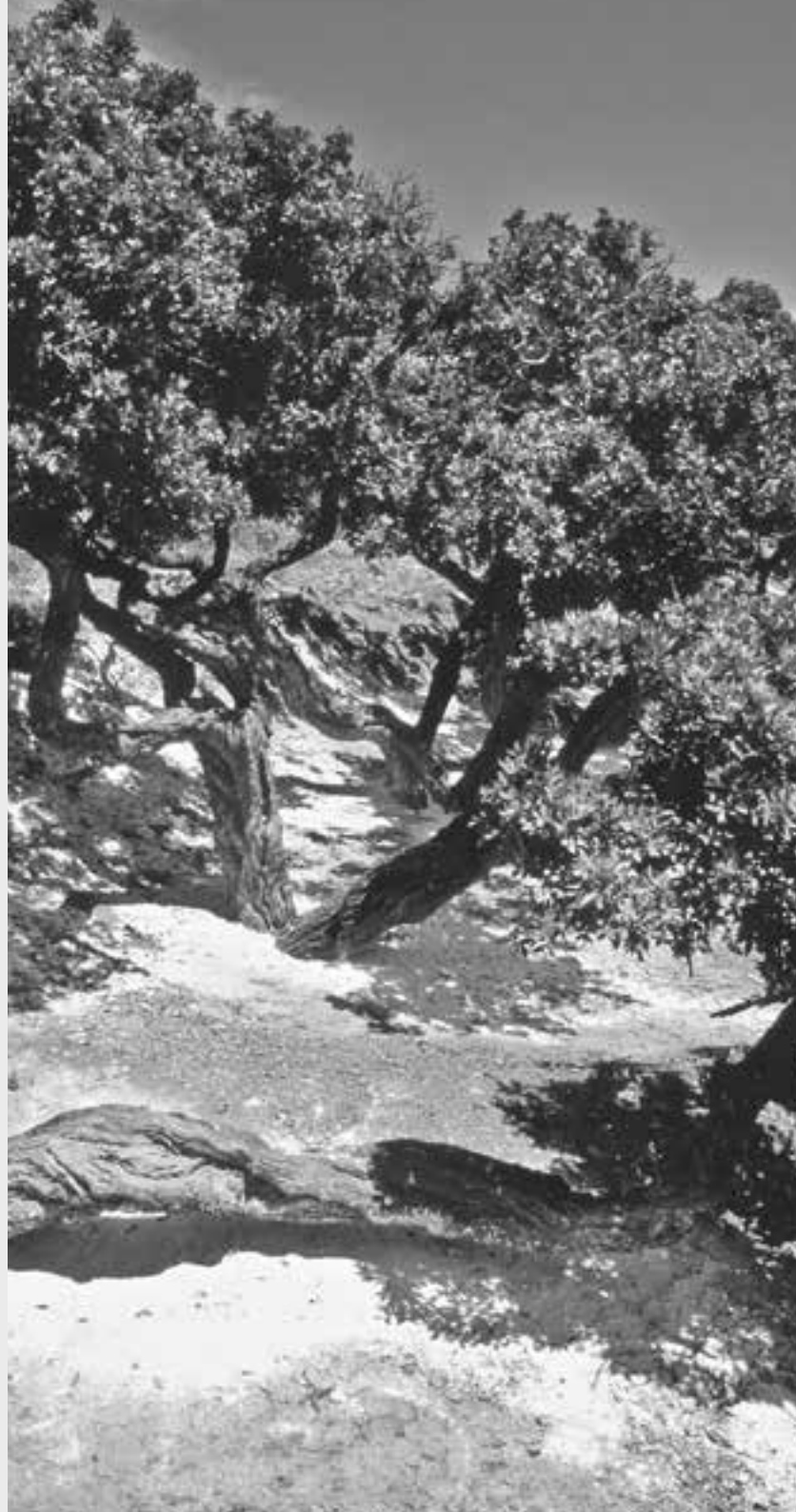

The Chios Mastic Museum in the region of the Mastichochoria presents the cultivation and processing of gum mastic as well as its integration to the cultural landscape of the island.

The permanent exhibition introduces the traditional know-how of the mastic tree cultivation, revealing how mastic shaped the rural and inhabited landscape of southern Chios. Thus, it sheds light on a significant aspect of Greece's production history and showcases the various uses of gum mastic.

The "culture of mastic" is highlighted in various ways: photographic and archival material, oral testimonies, audiovisual productions, multimedia applications, original machinery from old factories, still functioning. The museum experience is completed with the open-air exhibition where visitors actually have contact with the mastic tree and the natural environment in which it thrives.

The Know-How of Traditional Mastic Cultivation in Chios has been inscribed on the Representative List of Intangible Cultural Heritage of Humanity by UNESCO (2014).





## The **SILVERSMITHING** Museum



The Silversmithing Museum is housed in the western rampart of the southeastern acropolis (Its Kale) in the Castle of Ioannina. The two levels of the rampart and the old kitchens of the castle were restored in order to house the permanent exhibition, which presents the technology of silversmithing during the pre-industrial era, with an emphasis on the area of Epirus.

The first level is where the history and technology of silversmithing in Epirus is presented. Through the tools, the various techniques and with the help of photographs, audiovisual productions and multimedia applications, visitors discover the traditional techniques of shaping and decorating silverware. The second level is where the collection Epirote silverware from the 18th to the 20th centuries is presented. Works of art with intricate details, such as jewellery, weaponry, household silverware and personal items are some of the objects exhibited in this collection.





# The Historical Archives

The Historical Archives conserves the historical archives of banks incorporated by the Piraeus Bank Group as well as the archives of significant organizations and companies that were connected to it. In this way, the Archives contributes to the documentation and study of the economic history of Greece during the 20th century in general, with an emphasis on agriculture, industry and banking.

The Historical Archives of PIOP is housed in a former industrial complex in the area of Tavros, which has been renovated and transformed to a cultural centre with the entire necessary infrastructure for public events and the safekeeping of archival materials.

The main institutions and structure of the Greece's economy, the country's agricultural and industrial policy over the decades, important aspects of the banking system, the financial compensation of the refugees from Asia Minor, the agricultural cooperative movement, the foreign aid that Greece received after World War II and its management are some of the topics that can be researched here.

The Historical Archives of PIOP is open to the community of research, academics and education as well as the wider public, and it aims to contribute to the culture of history. This aim is served through a wide variety of activities. The Archives provides scientific consultancy in relation to the management of archives and depositories.

Adhering to the policy of "open archives", the Historical Archives of PIOP is organized according to international archival standards and is a member of the relevant associations. The collections are being enriched constantly with new acquisitions and donations. The digitized collections are accessible through the website <http://archives.piop.gr>





Μαγναλόγηρα ατμοκίνητα και ιπποκίνητα

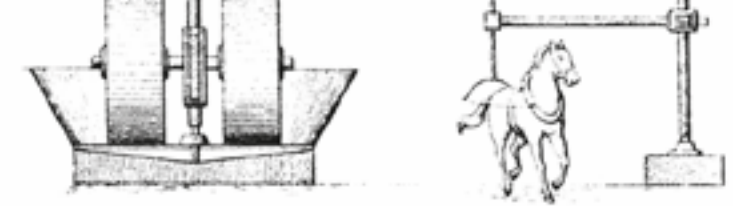

Ἐλατοτριβείον Ιπποκίνητον μετὰ ἱμπίσου κινήσεως

Τοιοῦτον κατασκευάζεται δι' ἀπενθείας κινήσεως μετὰ λιθίνην βόλον (ἀλάνη).

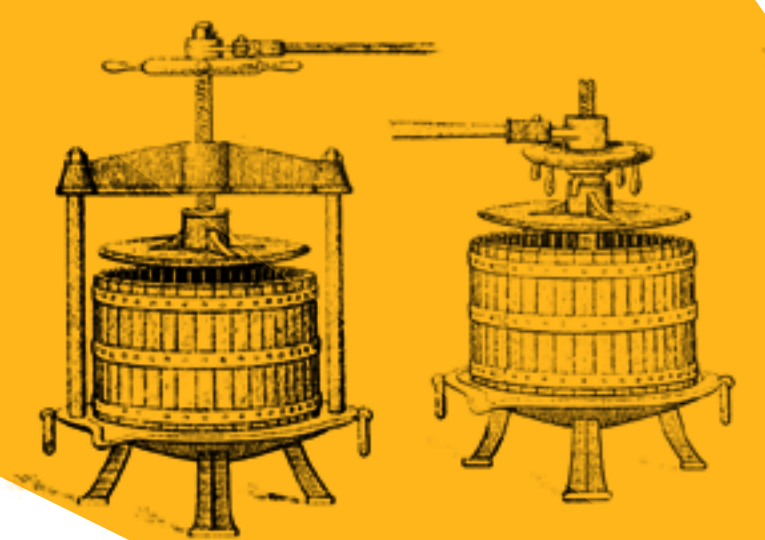

Συμφυλοπιστήρια τελευταίου συστήματος μετὰ χυτοσιδηρῆς βάσεως εἰς τρία μεγέθη

Συμφυλοπιστήρια τελευταίου συστήματος μετὰ χυτοσιδηρῆς βάσεως εἰς ἑπτὰ μεγέθη

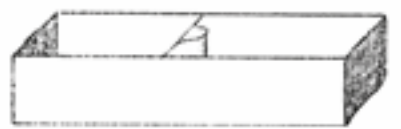

Λίμπα ἐκ χαλκοβελανιδίου

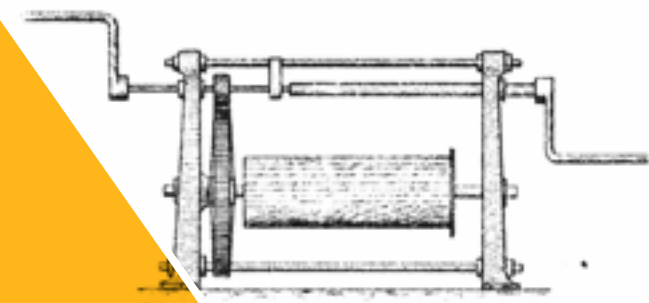

Ἐκχυστικὸν χειροκίνητον

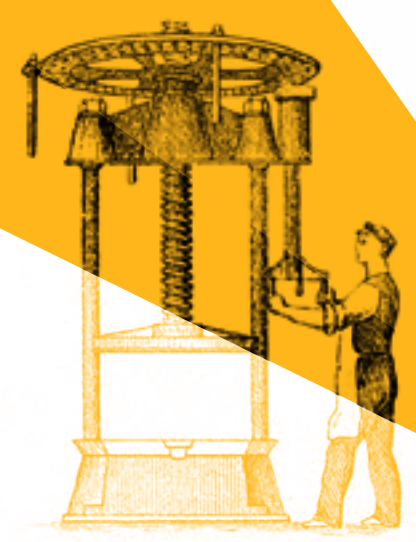
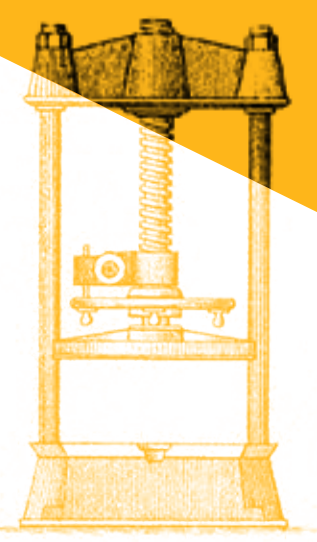
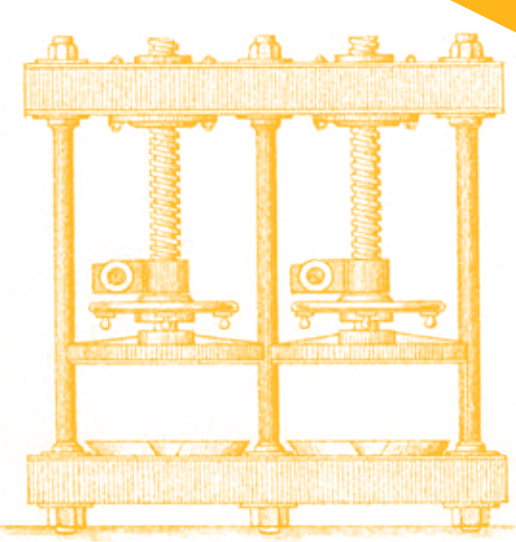

Ἐλατοπιεστήριον

Ἐλατοπιεστήριον

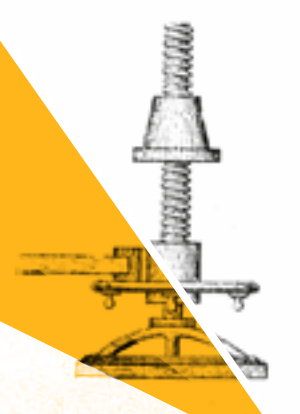

Ἐξαρτήματα ἐλατοπιεστήριου

# Research

The Research Programmes are designed on an interdisciplinary basis, in collaboration with universities, research centres and selected scientific entities, also catering to the activities of the Foundation. In addition, PIOP participates actively in research programmes that are financed by the European Union and the Operational Programmes of National Strategic Reference Frameworks (NSRFs).

The main pillars of the Programmes are:

- the recording, preservation and showcasing of traditional and pre-industrial technology.
- the study of technical and economic aspects of Modern Greek society.
- the linking of culture with the environment and the common management of cultural and natural heritage.

The Research Programmes focus on the following research fields:

- industrial archaeology
- pre-industrial production
- technology and traditional techniques
- new technologies that assist the highlighting of aspects of culture
- museology
- material culture
- cultural and environmental management
- economic history
- intangible cultural heritage



# Publications

The editorial series of the Foundation are the following:

- **Museology:** textbooks and seminal treatises on museum studies and cultural management.
- **Contributions:** collective editions or monographs resulting from the triptych research-exhibition-publication.
- **Our Museums:** monographs on the themes of the Museum Network (guidebooks etc.).
- **Monographs:** original treatises by Greek scholars and collective editions resulting from wider scientific research.
- **Records of Industrial Heritage:** descriptions and plans of historical industrial complexes in order to showcase and safeguard our architectural heritage.
- **Intangible Cultural Heritage:** studies on elements inscribed on the National and Global Representative List of Intangible Cultural Heritage of UNESCO, and translations of related works.
- **Historical Centres:** studies on significant historical centres.
- **Reference Points:** reprints of old and out-of-print Greek editions about the history of the Greek economy and industry.
- **Conference Proceedings:** proceedings of the Three-Day Workshops or of conferences organized by the Foundation or by other scientific institutions.
- **Educational Packs:** they support the educational programmes organized by the Museums of the Network and are sent free of charge to schools.
- **Science and Technology:** translations of classic textbooks on industrial archaeology and the history of techniques.
- **"Technologia" [Technology] Bulletin:** 11 issues of a periodical (1987-2001), with texts about the techniques and production in pre-industrial and industrial archaeology.
- **Cultural Guides:** guides of various areas of special interest for local history.
- **Cultural Landscapes:** new series of editions related to UNESCO.
- **Tales for Children:** inspired by the themes of the PIOP Museums.





# Library

The Library numbers about 60,000 Greek and foreign-language books and periodicals. It is open to the public, easily accessible, has a reading room and a children's section for the Foundation's younger friends. The Library's catalogue is enriched constantly by the purchase of new titles as well as through the exchange of books with other institutions.

**Titles in the Library are related to the following scientific fields:**

- agricultural economy and policy • anthropology • intangible cultural heritage
- industrial archaeology • geotechnical and environmental issues • ethnology
- history of technology • folklore • museology • economic and social history
- cultural management • banking and economics • finance

A significant legacy to the Library is the Zografos Collection, comprising rare books from the late 19th century in relation to the agrarian question in Greece as well as agricultural and historical subjects.





# Academic and Cultural Activities

The Piraeus Bank Group Cultural Foundation organises a variety of academic, educational, cultural and artistic activities in all its venues. In parallel, the Foundation promotes collaboration with local societies in the regions where it is active, and it also hosts their own cultural initiatives.

**These activities comprise the following:**

- temporary exhibitions, in cooperation with cultural institutions in Greece and abroad.
- scientific events on areas such as industrial heritage, traditional Greek technology, cultural and environmental management, economic history, the history of Greek products etc.
- thematic tours with an emphasis on the historical centre of Athens and the cultural depository of the areas where the Museums of the Foundation are located.
- cultural walks inspired by the archival material of the Historical Archives.
- artistic events such as theatre and dance performances, musical events, storytelling.
- film screenings (documentaries, Greek and foreign films, children's cinema).
- creative workshops.
- presentations of the Foundation's publications.





# Educational Programmes

Every thematic museum designs a journey throughout the production history of the country. The educational programmes comprise games and activities, and stimulate children of all ages. Thanks to these programmes, children acquire the chance to use tools and become initiated in processes and mechanisms of technical culture.

In addition, there are special educational activities that are organized in the context of PIOP's participation in European and international events and celebrations as well as summer workshops in the Museums of the Network.

PIOP designs and offers free of charge programmes and workshops to students of all ages and to adults in Athens, Thessaloniki and throughout the Museum Network. All educational programmes are approved by the Ministry of Education and Religions.



# Certifications and Awards

The Piraeus Bank Group Cultural Foundation has developed and applies:

- a Quality Management System according to the EN ISO 9001:2015
- a Sustainable Management System for events according to ISO 20121: 2012

Both of these Management Systems are surveyed and certified annually by TÜV AUSTRIA HELLAS.

Furthermore, the Foundation has developed and applies an Environmental and Energy Management System which organizes in the most systematic manner the survey, management and ultimately reduction of environmental consequences related to the Foundation's activities, while also improving its energy performance. The Environmental and Energy Management System has been certified by the Cyprus Certification Company [reg. no. EMAS ELV-0009 (number 549)] as per the following:

- CYS EN ISO 14001:2015
- CYS EN ISO 50001:2018
- IQNet

The Foundation has been included in the Greek register of EMAS (entry number EL-000110), according to Ministerial Decree 50486/1466/27.10.2014.

In 2012 the Piraeus Bank Group Cultural Foundation was awarded Europa Nostra award in the category "Dedicated Service".

In December 2018 the Academy of Athens awarded the Silver Medal of the Order of Letters and Arts to the Piraeus Bank Group Cultural Foundation.

In 2019 the Hellenic Section of the International Council of Museums (ICOM) selected the Piraeus Bank Group Cultural Foundation as honoured institution within the framework of the International Museum Day that was celebrated on the theme "Museums as Cultural Hubs: The Future of Tradition".





# Museumshops

Jewellery, artwork, office supplies, original gifts, souvenirs and toys are some of the objects that you can find in the Museum Shops of PIOP. They are special creations related to the nine Museums of the Foundation. Most of these tasteful objects have been designed exclusively for PIOP by new artists. In the Museum Shops you can also find all the publications of the Foundation. You can find your favourite objects at one of the eleven sale points in Athens, Thessaloniki, the nine museums of the Network and the e-shop.

## **Museum Shop Athens**

Spyromiliou Arcade, ground level,  
tel.: +30 210 3224 923

## **Museum Shop Thessaloniki**

9<sup>A</sup> Nikis Avenue & Dimosthenous,  
tel.: +30 2310 527 536

## **e-shop**

[www.piopmuseumshop.gr](http://www.piopmuseumshop.gr)

[www.piop.gr](http://www.piop.gr)



**PIRAEUS  
BANK GROUP  
CULTURAL  
FOUNDATION**

**CENTRAL ADMINISTRATION:** 6 Ang. Geronta St., 105 58 Athens **Tel.:** +30 210 3256 922 **E-mail:** [piop@piraeusbank.gr](mailto:piop@piraeusbank.gr)

**HISTORICAL ARCHIVES:** 2 Doridos St. & 14 Eirinis Av., 177 78 Tavros, Athens **Tel.:** +30 210 9571 305 **E-mail:** [archivespiop@piraeusbank.gr](mailto:archivespiop@piraeusbank.gr)

**LIBRARY:** 72-74 Salaminos St., 176 75 Kallithea, Athens **Tel.:** +30 210 3739 651-2 **E-mail:** [piop\\_library@piraeusbank.gr](mailto:piop_library@piraeusbank.gr)

**THESSALONIKI OFFICE:** 5-7 Ethnikis Aminis St, 546 21 Thessaloniki **Tel.:** +30 2310 293 812